





1900 系列
使用说明书
INSTRUCTION MANUAL











安全注意事项

1. 安全操作的标志及含义

本使用说明书及产品所使用的安全标志是为了让您正确安全的使用产品，防止您及其他人受到伤害。标志的图案和含义如下：

 危险	如果忽视此标记而进行错误的操作，会导致人员的重伤或死亡。
 注意	如果忽视此标记而进行错误的操作，会导致人员的受伤和设备的损坏。
	该符号表示“应注意事项”。三角中的图案表示必须要注意的内容。（例如左边的图案表示：“当心受伤”）
	该符号表示“禁止”
	该符号表示“必须”。圆圈中的图案表示必须要做的内容。（例如左边的图案表示“必须接地”）

2. 安全注意事项

 危险	
	打开控制箱时，先关闭电源开关并将电源插头从插座上拔下后，等待至少 5 分钟后，再打开控制箱盖。触摸带有高电压的区域会造成人员受伤。
 注意	
使用环境	
	应避免在强电气干扰源（如高频焊机）的附近使用本缝纫机。 强电气干扰源可能会影响缝纫机的正常操作。
	电源电压的波动应该在额定电压的±10%以内的环境下使用。 电压大幅度的波动会影响缝纫机的正常操作，需配备稳压器。
	环境温度应在 0℃~45℃的范围内使用。 低温或高温会影响缝纫机的正常操作。
	相对湿度应在 35%~85%的范围内，并且设备内不会形成结露的环境下使用。 干燥、潮湿或结露的环境会影响缝纫机的正确操作。
	压缩空气的供气量应大于缝纫机所要求的总耗气量。压缩空气的供气量不足会导致缝纫机的动作不正常。
	万一发生雷电暴风雨时，关闭电源开关，并将电源插头从插座上拔下。雷电可能会影响缝纫机的正确操作。
安装	
	请让受过培训的技术人员来安装缝纫机。

	安装完成前，请不要连接电源。 如果误按启动开关，缝纫机动作会导致受伤。
	缝纫机头倒下或竖起时，请用双手操作。不要用力压缝纫机。 如缝纫机失去平衡，缝纫机滑落到地上会造成受伤或机器损坏。
	必须接地。 接驳地线不牢固，是造成触电或误动作的原因。
	所有电缆应固定在离活动部件至少 25mm 以外处。另外，不要过度弯曲或用卡钉固定得过紧。会引起火灾或触电的危险。
	请在机头上安装安全罩壳。
缝纫	
	本缝纫机仅限于接受过安全操作培训的人员使用。
	本缝纫机不能用于除缝纫外的任何用途。
	使用缝纫机时必须戴上保护眼镜。 如果不戴保护眼镜，断针时机针折断部分可能会弹入眼睛造成伤害。
	发生下列情况时，请立即切断电源。否则误按下启动开关时，会导致受伤。 1.机针穿线时 2.更换机针时 3.缝纫机不使用或人离开缝纫机时
	缝纫过程中，不要触摸任何运动部件或将物件靠在运动部件上，因为这会导致人员受伤或缝纫机损坏。
	如果缝纫机操作中发生误动作，或听到异常的噪声或闻到异常的气味，应立即切断电源。然后请与购买商店或受过培训的技术人员联系。
	如果缝纫机出现故障，请与购买商店或受过培训的技术人员联系。
维护和检查	
	只有经过训练的技术人员才能进行缝纫机的维修、保养和检查。
	与电气有关的维修、保养和检查请及时与电控厂家的专业人员进行联系。
	发生下列情况时，请关闭电源并拔下电源插头。否则误按启动开关时，会导致受伤。 1. 检查、调整和维修 2. 更换弯针、切刀等易损零部件
	在检查、调整和修理任何使用气动设备之前，请先断开气源，并等压力表指针下降到“0”为止。
	在必须接上电源开关和气源开关进行调整时，务必十分小心遵守所有的安全注意事项。
	未经授权而对缝纫机进行改装而引起的缝纫机损坏不在保修范围内。

1. 主机的名称

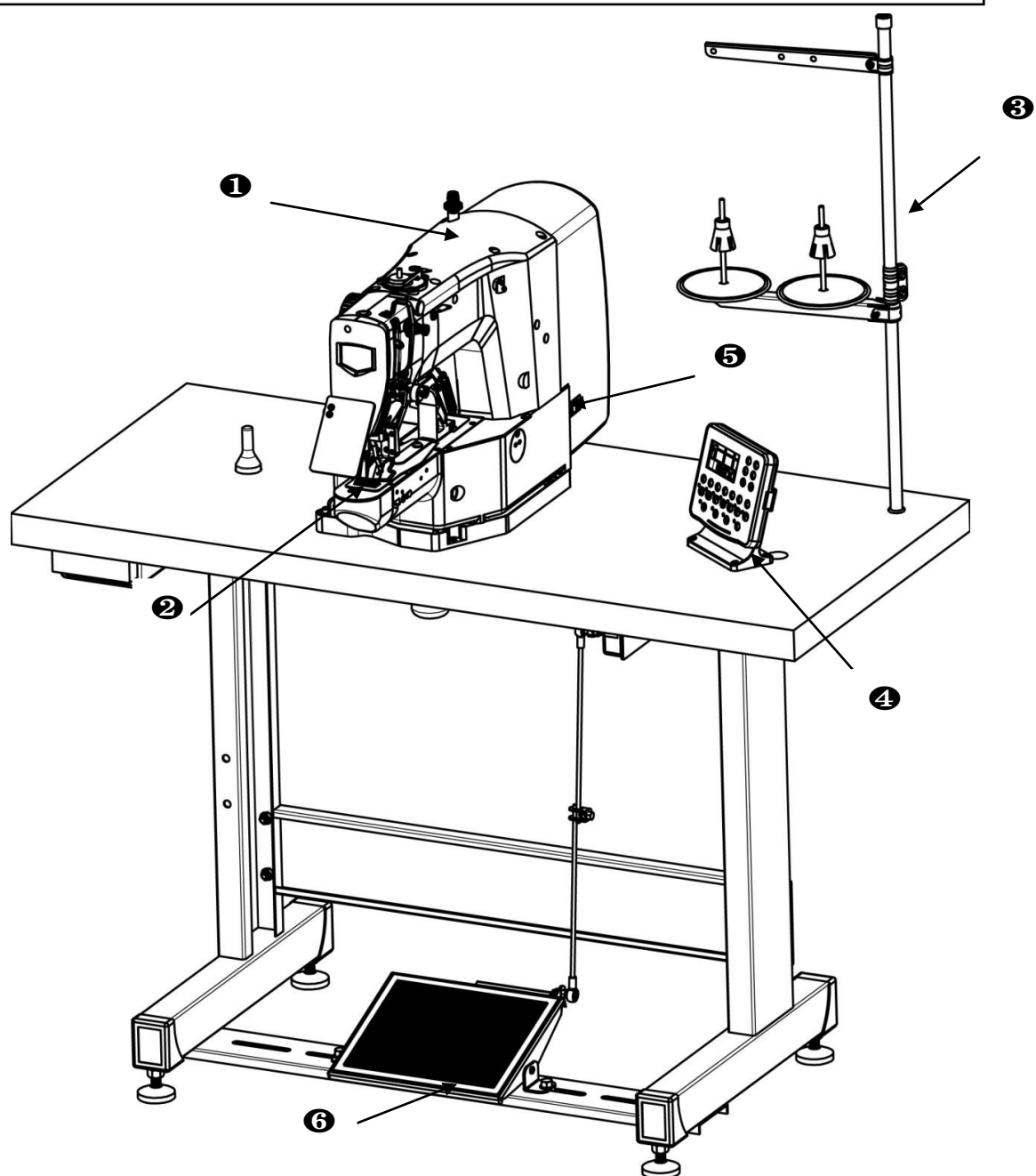

① 缝纫机机头

② 布压脚

③ 线架装置

④ 操作盘

⑤ 电源开关

⑥ 踏板

11. 安装

1. 脚踏板传感器的安装

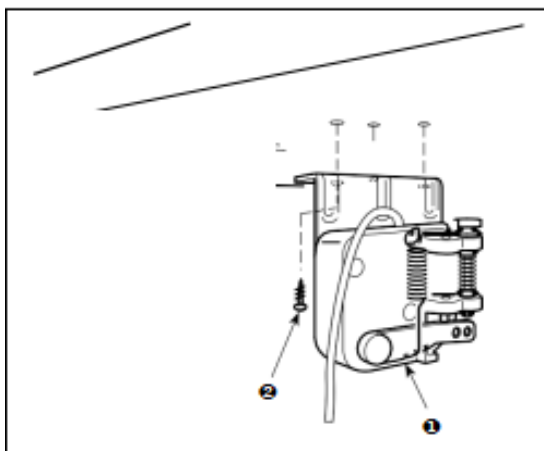

用附属的安装螺丝**②**，把踏板传感器**①**安装到机台上。

2. 连结杆的安装方法

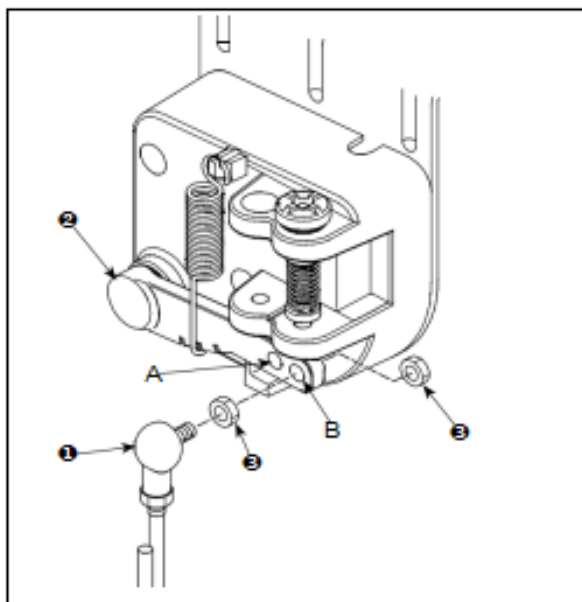

1、把连结杆**①**用螺母**③**固定到踏板拨杆**②**的安装孔 B 里

2、把连结杆**①**安装到安装孔 A 之后，踏板的踩踏行程变小

3. 机头部支杆的安装

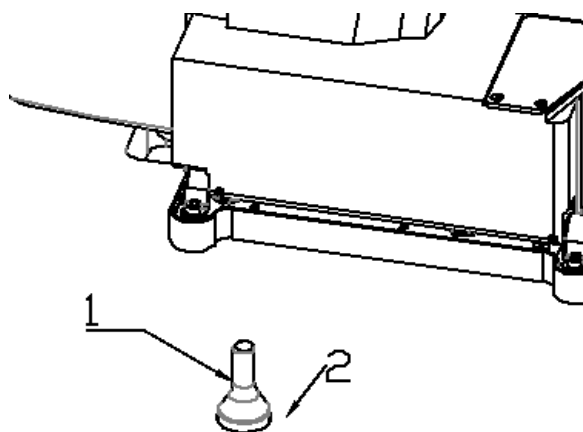

把机头部支杆**①**插到机台孔**②**里

4. 缝纫机的搬运方法

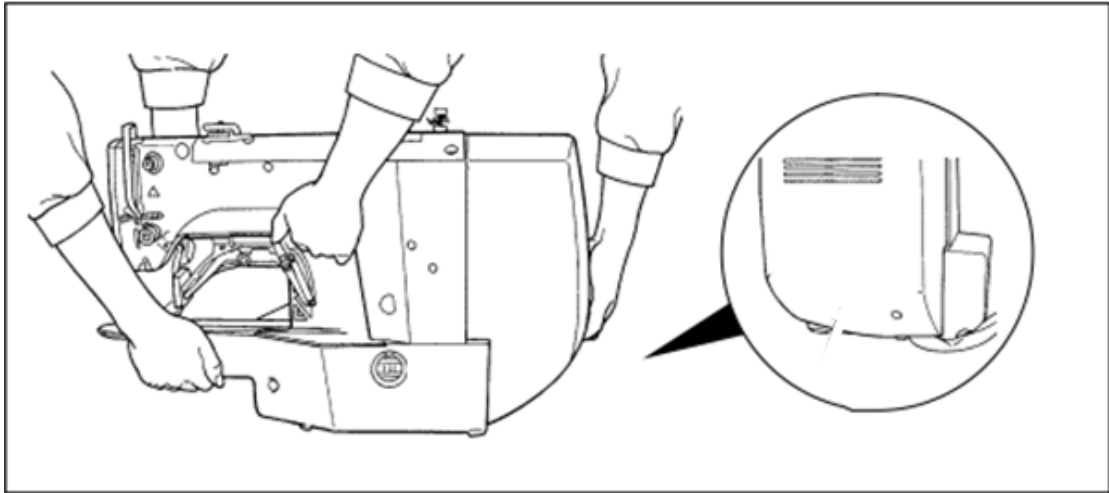

搬运缝纫机时，请如图所示那样。

1. 请注意不要让拿着护罩的手发生滑动。
2. 缝纫机的重大达 42kg 以上，因此请一定用 2 个人以上来搬运。

5. 缝纫机头的安装方法

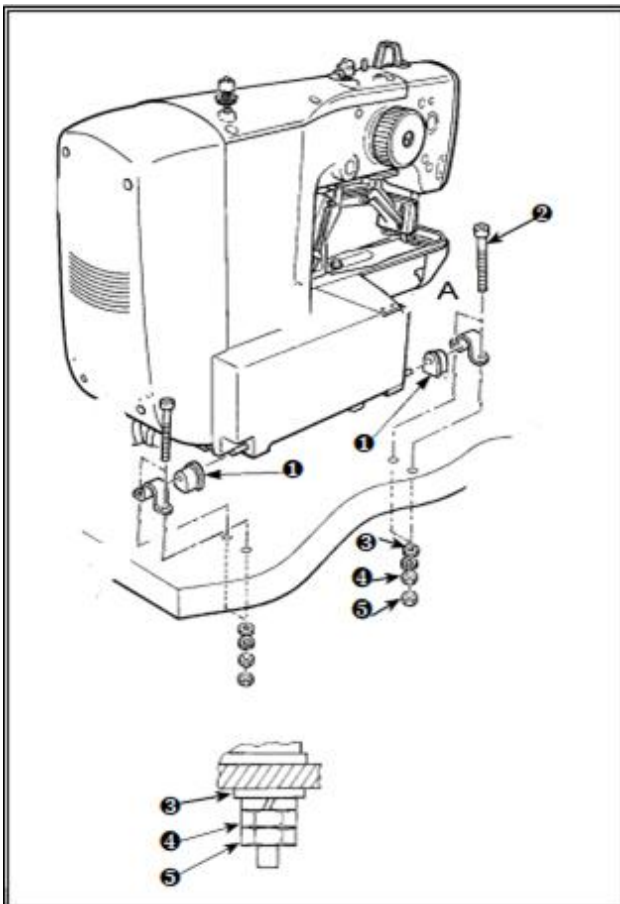

把铰链防震橡胶①插到铰链轴上。
用附属的 4 个螺栓②、4 个平垫片③、4 个六角螺母④和 4 个六角螺母⑤把缝纫机主机安装到机台上

6. 废油槽和机头支撑橡胶的安装

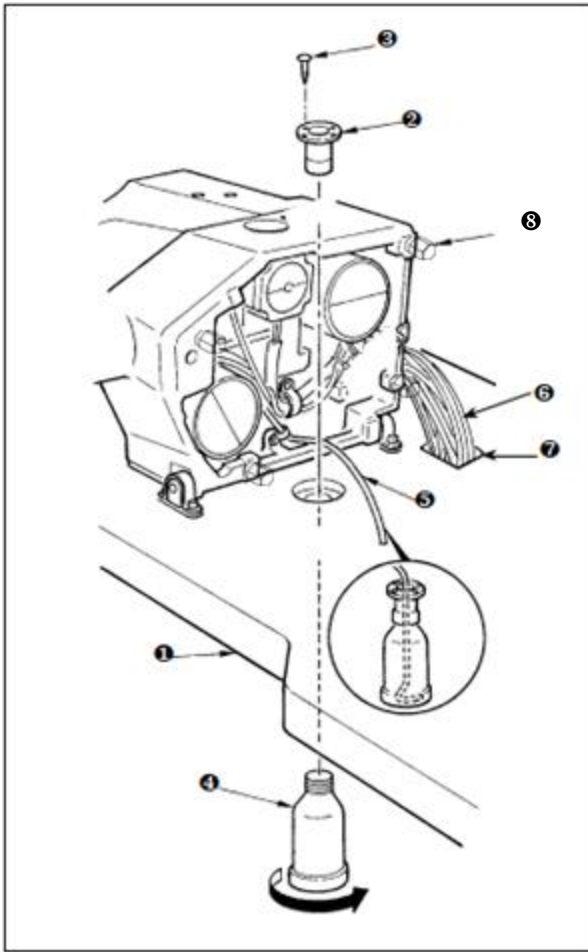

- 1)用固定螺丝**③**（2个）把废油槽**②**固定到机台**①**的安装孔上。
- 2)把废油杯**④**拧进废油槽**②**。
- 3)把缝纫机废油管**⑤**插到废油杯**④**里。
- 4)请把电线捆**⑥**穿过机台的长孔**⑦**。

注意！

- 1.放倒缝纫机机头后，废油管**⑤**应该不从废油销**④**脱落，牢牢地插到最里面
- 2.请卸下固定废油管**⑤**的胶带。

7. 缝纫机头的放倒方法

放倒缝纫机和抬起缝纫机时，请注意不要让缝纫机夹住手指。同时，为了防止突然的起动发生意外的事故，请把电源关掉之后再进行操作。

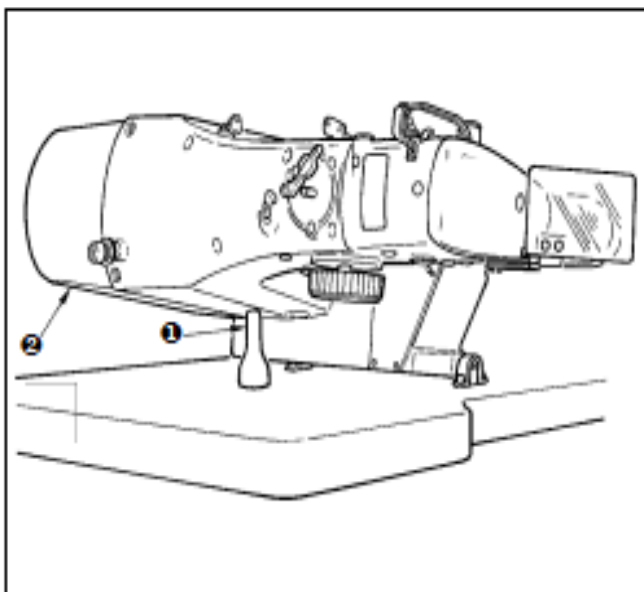

放倒缝纫机时，请轻轻地放，把缝纫机放在机头支杆**①**上。

注意！

- 1.倒缝纫机前，请先确认机台上是否安装有机头支杆**①**。
- 2.抬起缝纫机时，请不要搬马达外罩**②**来抬起缝纫机，以免防止马达外罩**②**损坏。
- 3.为了防止机器翻倒，请一定在平坦的地方放倒缝纫机。

8. 操作盘的安装

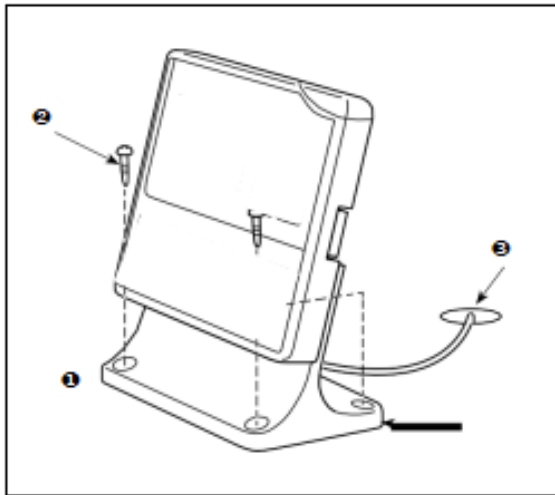

用 4 个木螺丝**②**把操作盘安装板**①**固定到机台上，然后把电缆线穿过机台孔**③**

9. 眼睛保护罩的安装

为了保护断针飞起弄伤眼睛，请一定安装起来

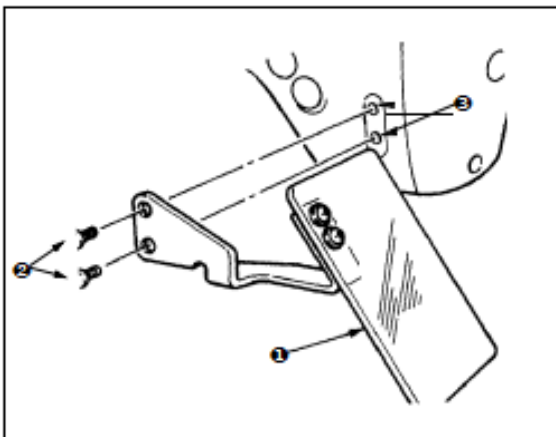

请一定把眼睛防护罩**①**用螺丝**②**安装到安装部**③**之后再使用缝纫机

10. 线架的安装

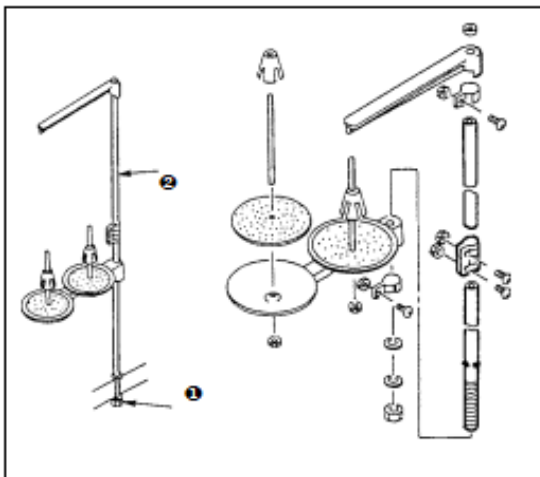

1) 如图所示那样把线架安装到机台孔上。

2) 用固定螺母**①**固定线架。

顶线配线时，请把电源线从线架杆**②**中穿过

III. 缝纫机的准备

1. 加油方法

警告：为了防止突然的启动造成人身事故，请关掉电源后再进行操作

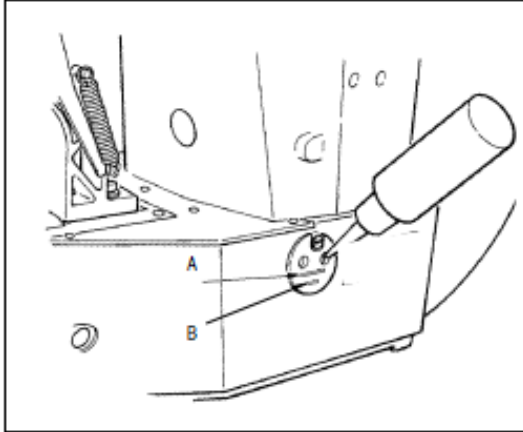

请确认机油在下线 B 和上线 A 之间。如果机油过少时，请用附属的加油器进行加油。
* 加油的油槽仅是向旋梭加油的。使用低速时，如果旋梭的油量过多，可以把油量调小。

注意！

1. 请注意不要向油槽和下列注意 2 的旋梭以外的部位加油。否则会发生零件故障。
2. 初次使用缝纫机或较长时间没有使用缝纫机时，请向旋梭加少量的机油后再使用缝纫机

2. 机针的安装

警告：为了防止突然的启动造成人身事故，请关掉电源后再进行操作

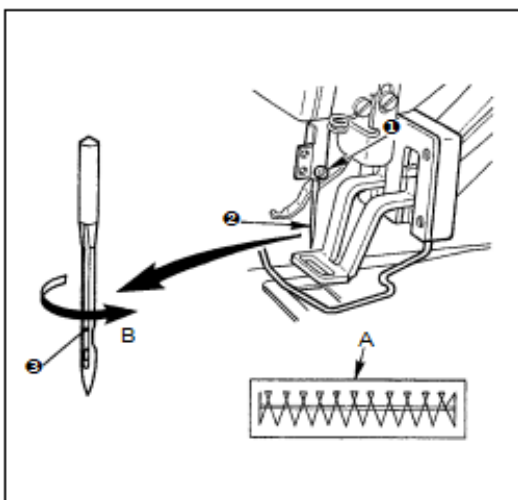

安装机针时，请拧松固定螺丝①，把机针②的长沟③朝向面前，插进针杆的深处，然后拧紧固定螺丝①。

注意！

缝迹如 A 时，请把机针向 B 方向稍稍移动然后安装起来。

3. 上线的穿线方法

警告：为了防止突然的启动造成人身事故，请关掉电源后再进行操作

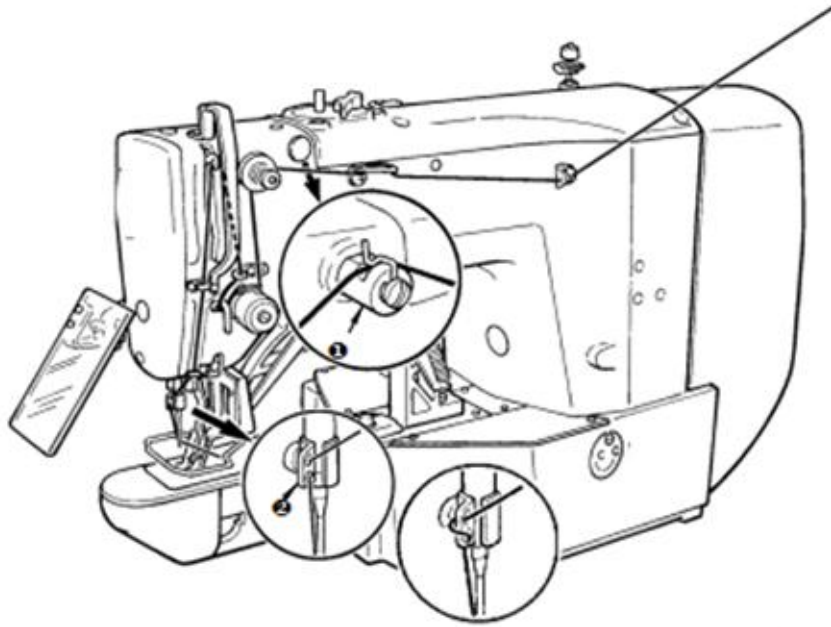

穿过机针的线应留出 40mm 左右。

注意：

- 1.使用硅油时，请把线穿过润滑导线器①。（选用品）
- 2.粗线时，请把机线只穿过针杆导线器② 1 个孔

4. 梭壳的取下插入

警告：为了防止突然的启动造成人身事故，请关掉电源后再进行操作

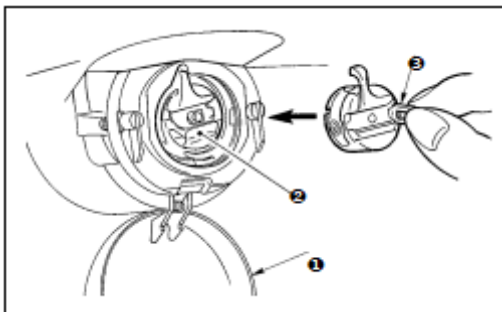

- 1) 打开旋梭外罩①。
- 2) 拨起旋梭壳②的抓脚③，取出梭壳。
- 3) 插入时，请把梭壳深深插入旋梭轴，并关闭抓脚

注意！

如果没有插到底，缝制途中梭壳②就有可能脱落

5. 旋梭的插入方法

警告：为了防止突然的起动造成人身事故，请关掉电源后再进行操作

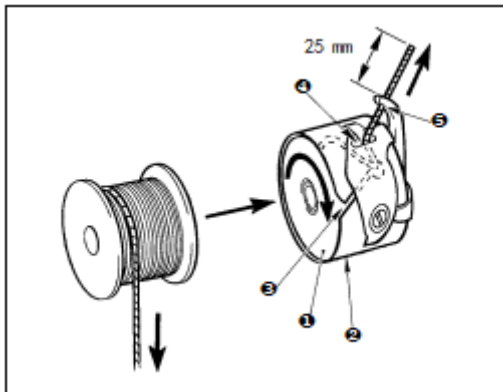

- 1) 把旋梭**①**按图示的方向插入梭壳**②**。
- 2) 把线穿过梭壳**②**的穿线口**③**，然后拉线，把线从线张力弹簧下面的穿线口**④**拉出来。
- 3) 把线从角部的线孔**⑤**穿出，从线孔约拉出25mm。

注意！

旋梭的旋转方向相反的话，底线的拉出就不稳定

6. 线张力的调整方法

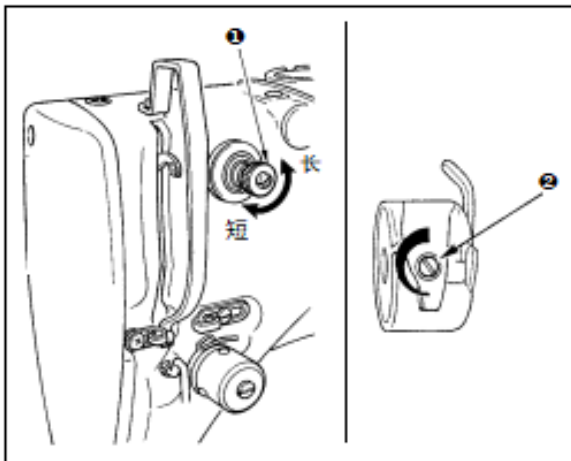

把第一线张力旋钮**①**向右转动，切线后针尖上的残线长度变短，向左转动后变长。

请尽量在不脱线的情况下弄短残线。

在操作盘上调整上线张力，用**②**调整底线张力

7. 挑线弹簧的调节

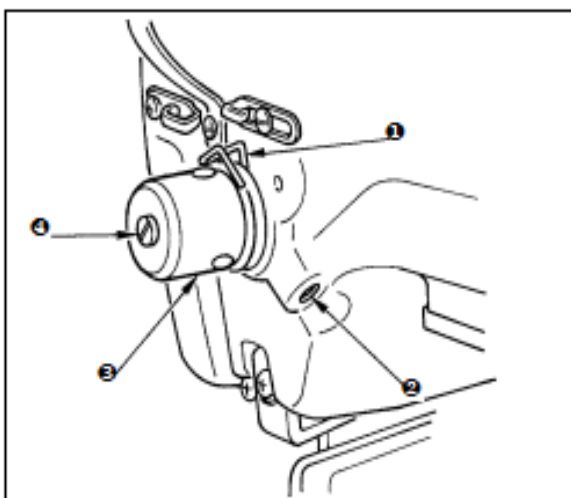

挑线弹簧**①**的标准移动量为 8 ~ 10mm，开始挑线时的强度为 0.1 ~ 0.3N。

1) 移动量的调节

拧松固定螺丝**②**，转动线张力结合体**③**。向右转动之后，动作量变大，拉线量变多。

2) 强度的调节

改变挑线弹簧的强度时，请在螺丝**②**拧紧的状态下，把细螺丝刀插到线张力杆**④**的缺口部转动调节。向右转动之后，挑线弹簧的强度变强，

向左转动之后，强度变弱

8. 缝制张力例

初次使用时，请参考下表调整缝制张力

机线	布料	设定上线张力	挑线弹簧的动作量 [拉线量]	强度
聚酯长纤维线 #50	毛	30 ~ 35	10mm [13mm]	0.1N
聚酯短纤维线 #50	毛	50 ~ 55	10mm [13mm]	0.2N
聚酯短纤维线 #60 (抓线 OFF)	T/C 宽带	30 ~ 35	8 ~ 10mm [11 ~ 13mm]	0.1N
棉线 #50	牛仔布	35 ~ 45	10mm [13mm]	0.1N
棉线 #20	牛仔布	35 ~ 45	8 ~ 10mm [11 ~ 13mm]	0.1N

IV. 维修

1. 针杆高度

警告：为了防止突然的起动造成人身事故，请关掉电源后再进行操作

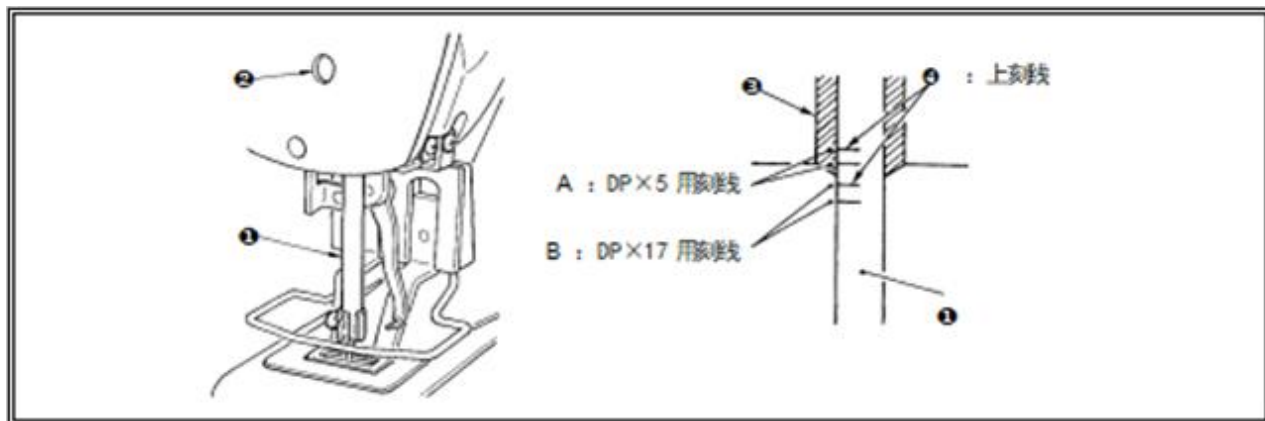

把针杆①设到最下点，拧松针杆紧固螺丝②，把针杆上刻线④和针杆下挡块③的下端调节成一致。

注意！

调节后请一定确认不要有松动

*有的缝制条件发生跳针时，请从针杆上刻线④往下调节 0.5 ~ 1mm

2. 针杆与旋梭

警告：为了防止突然的起动造成人身事故，请关掉电源后再进行操作

机针和刻线的关系



1.用手转动皮带轮，针杆①上升时，把下刻线②对准针杆下挡块③前端

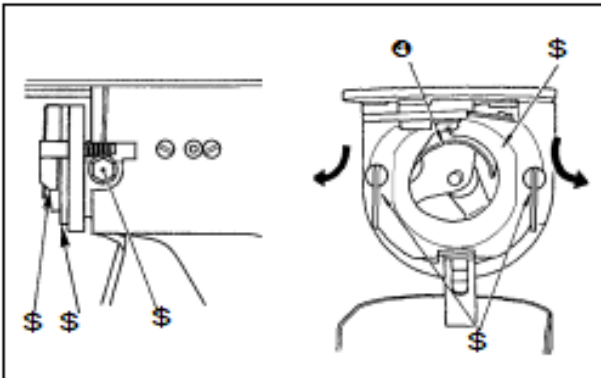

2.拧松驱动器固定螺丝\$, 左右打开中旋梭压片\$, 卸下中旋梭压脚\$

注意！
此时请注意不要脱落中旋梭④

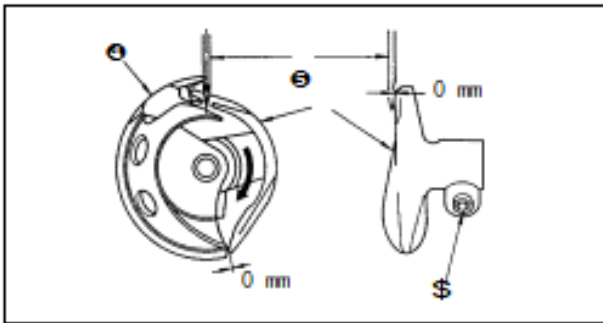

3.为了让中旋梭④的梭尖与针⑤的中心一致，同时防止驱动器⑥在前端面与机针相碰，弄弯机针，请把驱动器前端面与机针的间隙调整为 0mm，然后把驱动器固定螺丝\$拧紧

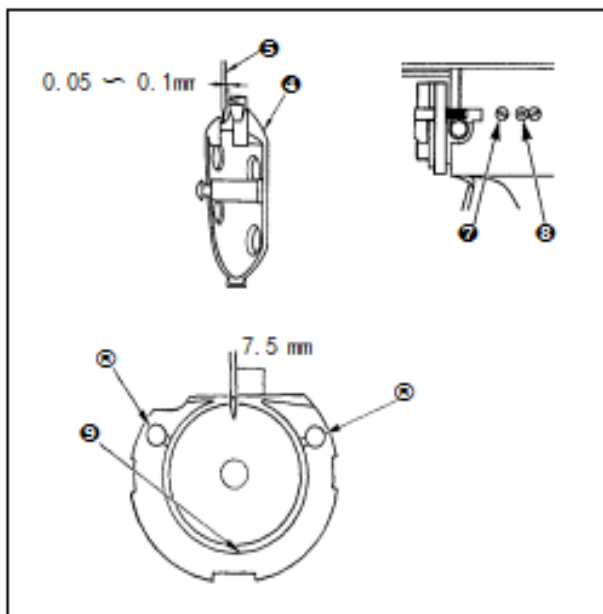

4.拧松大旋梭固定⑦，左右转动大旋梭调节轴⑧，调节大旋梭的前后位置，把机针⑤和中旋梭④的梭尖的间隙调整为 0.05 ~ 0.1mm。

5. 调节完大旋梭的前位置后，机针和大旋梭的间隙应为 7.5mm，然后拧紧大旋梭固定螺丝⑦

注意！
较长时间没有使用机器，或者清扫了旋梭部周围等情况后，请向旋梭圈部⑨和毡垫⑩加入少量的机油之后再使用。

3. 压脚的高度

警告：为了防止突然的起动造成人身事故，请关掉电源后再进行操作

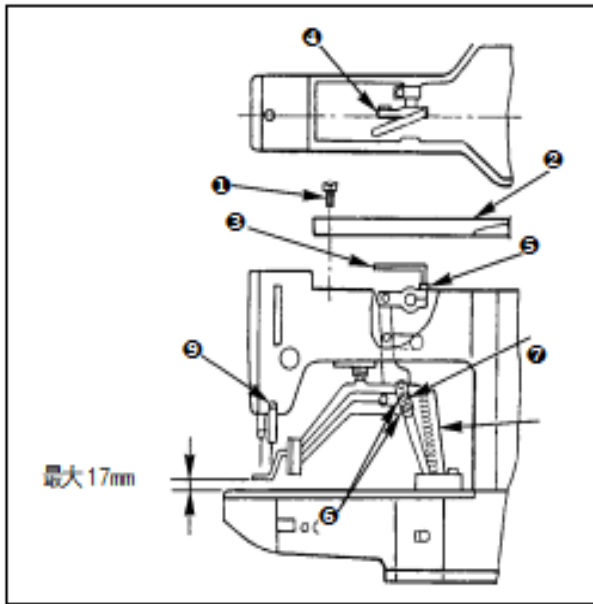

- 1) 在停止状态，卸下 6 根机架外罩固定螺丝①，然后卸下机架外罩②。
 - 2) 把 L 形扳手③插入中央的紧固筒④的六角孔螺栓⑤，把它拧松。
 - 3) 把 L 形扳手③向下压布压脚升高，向上抬布压脚降低。
 - 4) 调节后，把六角孔螺栓⑤确实拧紧。
 - 5) 左右压脚不一致时，拧松固定螺丝⑥，调节布压脚拨杆挡板⑦调整高度注意！
- 此时，请不要让布压脚拨杆挡板⑦与送布台⑧相碰。如果和挑线杆相碰，请用挑线杆安装台固定螺丝⑨调节挑线杆高度

4. 移动刀和固定刀

警告：为了防止突然的起动造成人身事故，请关掉电源后再进行操作

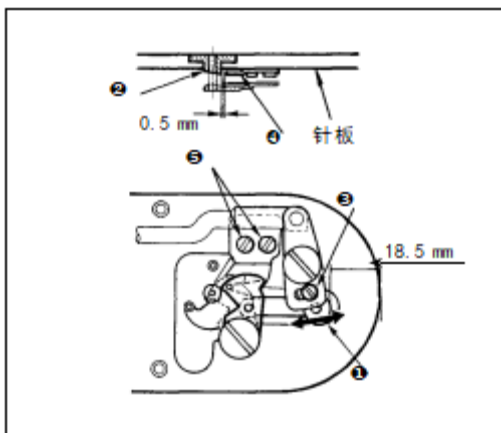

- 1) 拧松调节螺丝③，向箭头方向移动活动刀，把从针板前端到切线小拨杆①前端的距离调整为 18.5mm。
- 2) 拧松固定螺丝⑤，移动固定刀，把针孔导线器②和固定刀④之间的间隙调整为 0.5mm

5. 废油的处理

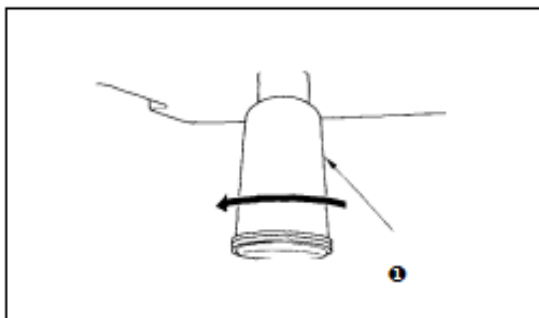

积油杯**1**里积满了油之后，请卸下积油杯**1**排放出废油

6. 旋梭的加油量

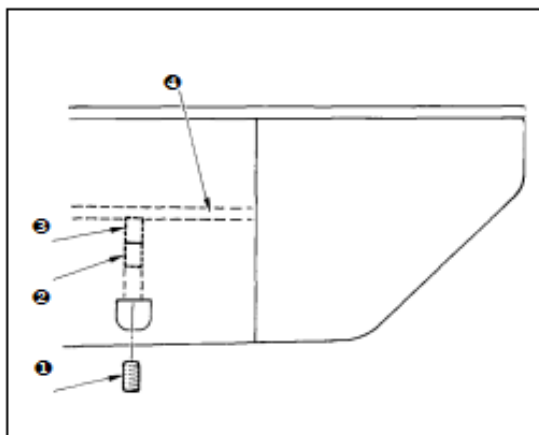

- 1) 拧松固定螺丝**1**，卸下固定螺丝**1**。
- 2) 拧紧调整螺丝**2**之后，加油管左**4**的油量被弄小。
- 3) 调整后，拧紧固定螺丝**1**固定好。





注意！

- 1.在标准出货状态，轻轻拧紧**3**回转 4 圈的位置。
- 2.弄小油量时，不要一次拧紧，拧紧**3**回转 2 圈，待半日左右观看一下。拧得过紧的话会磨损旋梭









Safety Matters for Attention







1. Signs & Definitions of Safety Marks







This User's Manual and the Safety Marks printed on the products are to enable you to use this product correctly so as to be away from personal injury. The signs and definitions of Marks are shown in below:







 Danger	The incorrect operation due to negligence will cause the serious personal injury or even death.
 Caution	The incorrect operation due to negligence will cause the personal injury and the damage of mechanism.
	This kind of marks is "Matters for Attention", and the figure inside the triangle is the content for attention. (Exp. The left figure is "Watch Your Hand!")
	This kind of mark is "Forbidden".
	This kind of mark means "Must". The figure in the circle is the contents that have to be done. (Exp. The left figure is "Ground!")

2. Safety Matters for Attention

 Danger Danger	
	For opening the control box, please turn off the power and take away the plug from socket firstly, and then wait for at least 5 minutes before opening the control box. Touching the part with high voltage will cause the person injury.
 Caution Caution	
Usage Environment	
	Try not to use this sewing machine near the sources of strong disturbance like high-frequency welding machine. The source of strong disturbance will affect the normal operation of the sewing machine.
	The voltage fluctuation shall be within 10% of the rated voltage. The large fluctuation of voltage will affect the normal operations of sewing machine, Therefore a voltage regulator is needed in that situation.
	Working temperature: 0°C ~ 45°C. The operation of the sewing machine will be affected by environment with temperature beyond the above range.
	Relative Humidity: 35% ~ 85% (No dew inside the machine), or the operation of sewing machine will be affected.
	The supply of compressed gas shall be over the consumption required by the sewing machine. The insufficient supply of compressed gas will lead to

	the abnormal action of sewing machine.
	In case of thunder, lightning or storm, please turn off the power and pull plug out the socket. Because these will have influence on the operation of sewing machine.
Installation	
	Please ask the trained technicians to install the sewing machine.
	Don't connect machine to power supply until the installation is finished. Otherwise the action of sewing machine may cause personal injury once the start switch is pressed at that situation by mistake.
	When you tilt or erect the head of sewing machine, please use both of your hand in that operation. And never press the sewing machine with strength. If the sewing machine loses its balance, it will fall into floor thus causes the personal injury or mechanical damage.
	Grounding is a must. If the grounding cable is not fixed, it may cause the electric-shock and mis-operation of machine
	The entire cables shall be fixed with a distance at 25mm away from the moving component at least. By the way, don't excessively bend or tightly fixed the cable with nails or clamps, or it may cause the fire or electric shock.
	Please add security cover on the machine head.

Sewing	
	This sewing machine can only be used by the trained staff.
	This sewing machine has no other usages but the sewing.
	When operating the sewing machine, please remember to put on the glasses. Otherwise, the broken needle will cause the personal injury in case the needle is broken.
	At following circumstances, please cut off the power at once so as to avoid the personal injury caused by the mis-operation of start switch: 1. Threading on needles; 2. Replacement of needles; 3. The sewing machine is left unused or beyond supervision
	At working, don't touch or lean anything on the moving components, because both of the above behaviors will cause the personal injury or the damage of the sewing machine.
	During working, if the mis-operation happens or the abnormal noise or smell is found at the sewing machine, user shall cut off the power at once, and then contact the trained technicians or the supplier of that machine for solution.

	<p>For any trouble, please contact the trained technicians or the supplier of that machine.</p>
<p>Maintenance & Inspection</p>	
	<p>Only can the trained technicians perform the repair, maintenance and inspection of this sewing machine.</p>
	<p>For the repair, maintenance and inspection of the electrical component, please contact the professionals at the manufacturer of control system in time.</p>
	<p>At following circumstances, please cut off the power and pull off the plug at once so as to avoid the personal injury caused by the mis-operation of start switch:.</p> <ol style="list-style-type: none"> 1.Repair, adjustment and inspection ; 2.Replacement of the component like curve needle, knife and so on
	<p>Before the inspection, adjustment or repair of any gas-driven devices, user shall cut off the gas supply till the pressure indicator falls to 0.</p>
	<p>When adjusting the devices needing the power supply and gas supply, users can' t be too careful to follow the entire Safety Matters for Attention.</p>
	<p>If the sewing machine damages due to the unauthorized modification, our company will not be responsible for it.</p>

I. INSCAPE

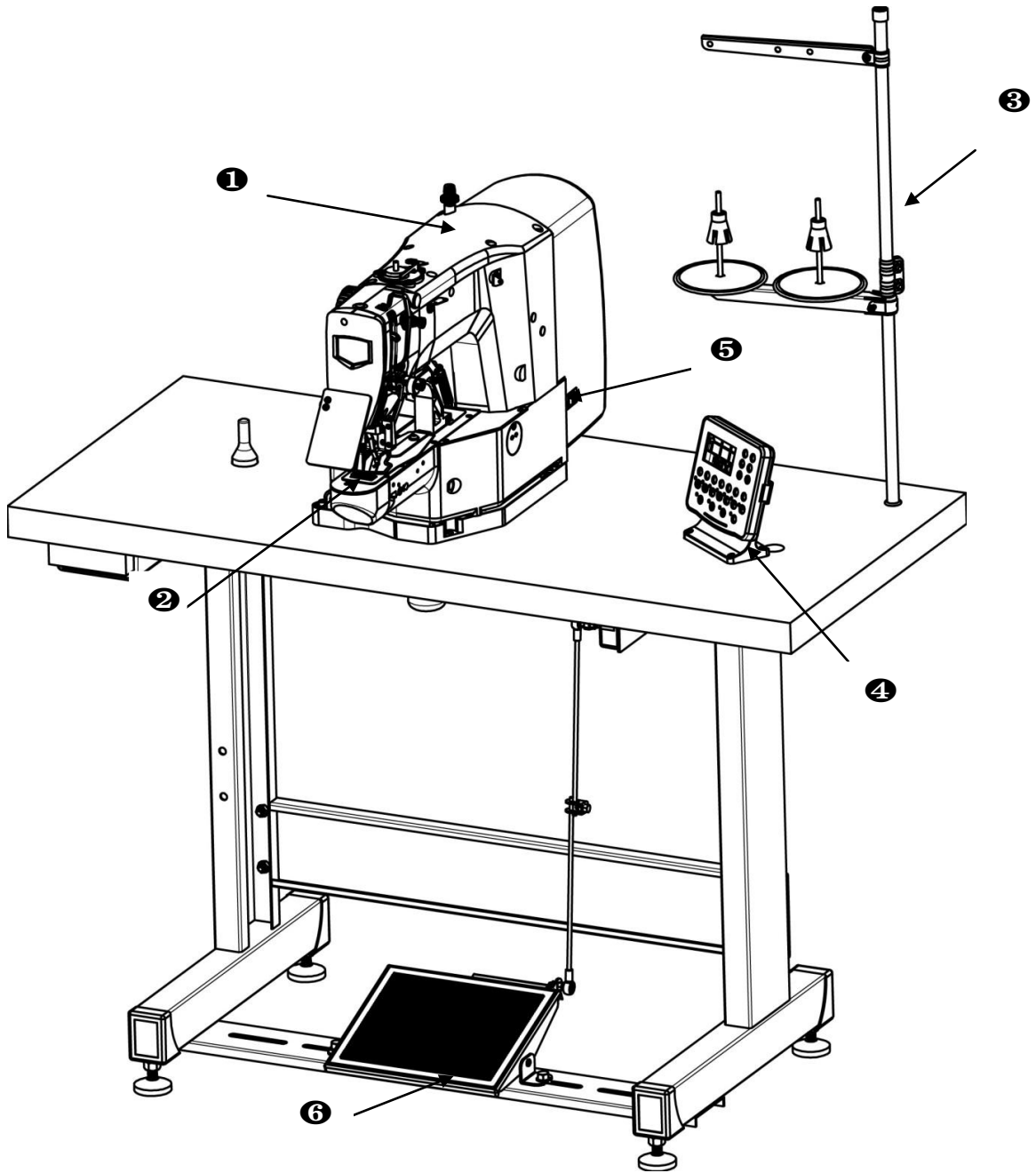

- ① Machine head
- ② Work clamp fee
- ③ Thread stand
- ④ Operation panel
- ⑤ Power switch
- ⑥ Pedal

II. INSTALLATION

1. Installing the pedal sensor

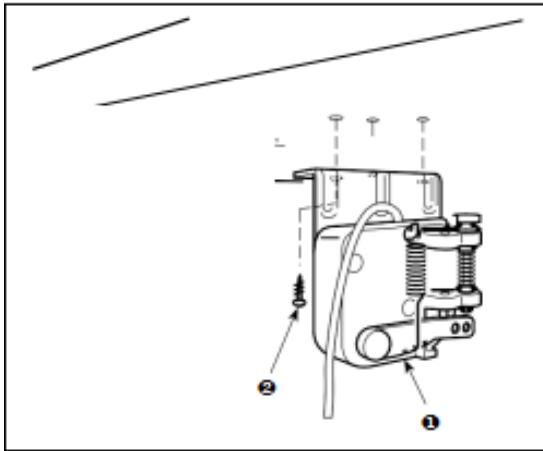

Install the pedal sensor **1** to the table with mounting screws **2** supplied with the unit.

2. Attaching the connecting rod

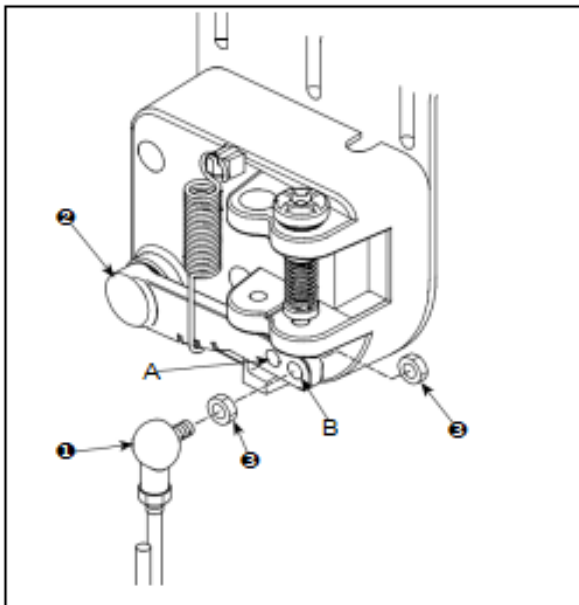

- 1) Fix connecting rod **1** to installing hole B of pedal lever **2** with nut **3**.
- 2) The pedal depressing stroke is decreased by fitting connecting rod **1** in mounting hole A.

3. Installing the head support rod

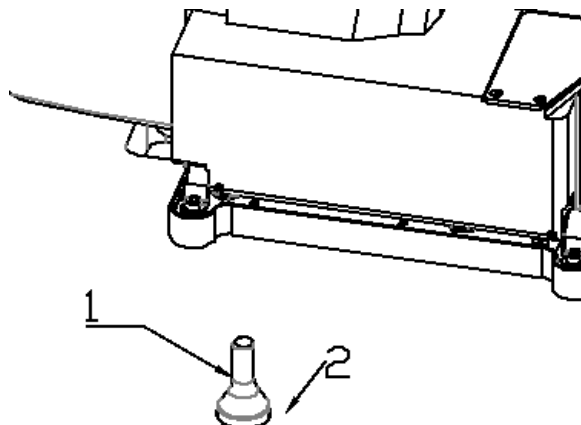

Drive head support rod **1** in hole **2** in the machine table.

4. How to carry the sewing machine

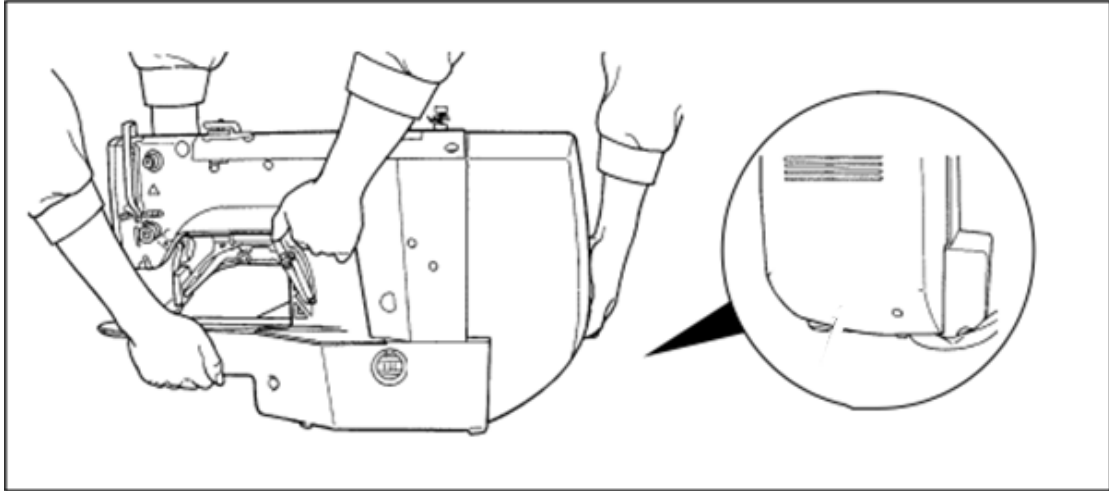

Please carry the sewing machine as shown in the figure.

1. Carefully prevent slippage of your hand that holds the cover.
2. The sewing machine weighs over 42 kg. Be sure to carry the sewing machine with two or more people without exceptions.

5. Installation of the sewing machine head

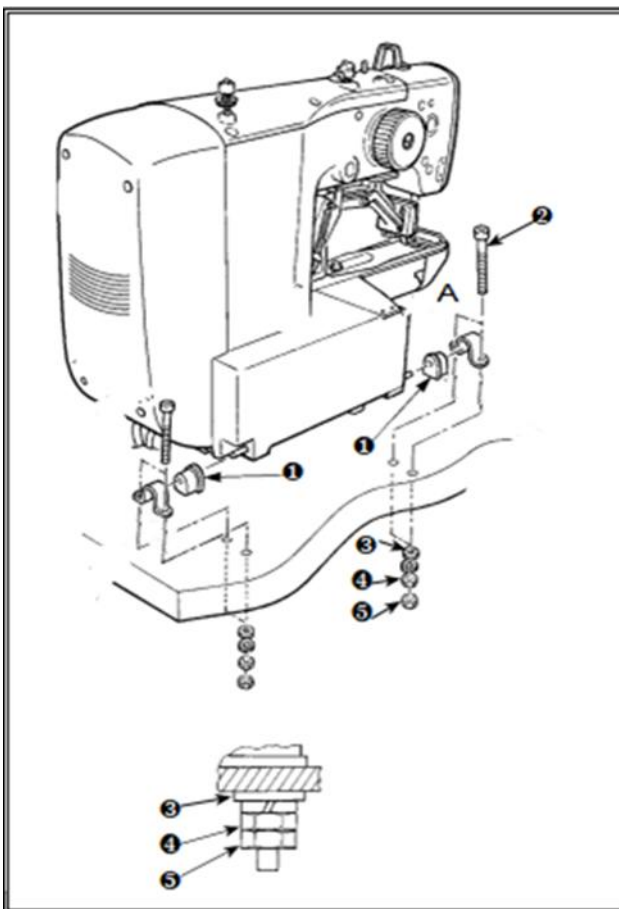

- 1) Fit hinge rubber cushion **①** over the hinge shaft.
- 2) Install the main body of the sewing machine on the table with four bolts **②**, four plain washers **③**, four hexagonal nuts **④** and four hexagonal nuts **⑤**

6. Installing the drain receiver and the head support rubber

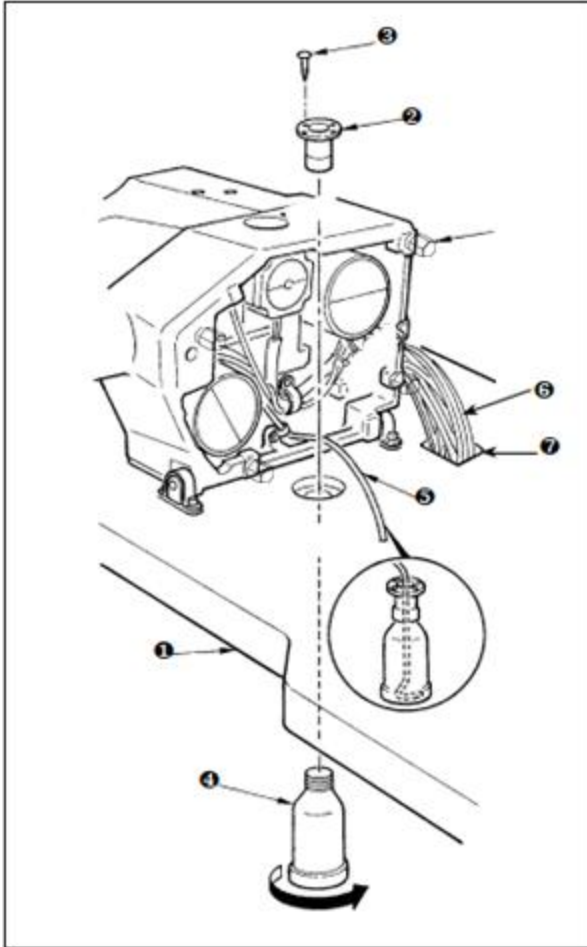

1) Fix drain receiver **2** in the installing hole of table

1 with two setscrews **3** .

2) Screw poly-oiler **4** in waste oil reservoir **2** .

3) Insert sewing-machine waste oil pipe **5** into poly-oiler **4** .

4) Insert head support rubber **6** into table **1** .

CAUTION !

1. Insert drain pipe **5** until it will go no further so that it does not come off poly-oiler **4** when tilting the machine head.

2. Remove the tape fixing drain pipe **5**

7. Tilting the sewing machine head

Tilt/raise the sewing machine head with both hands taking care not to allow your fingers to be caught in the head. Turn OFF the power before starting the work so as to prevent accidents caused by abrupt start of the sewing machine.

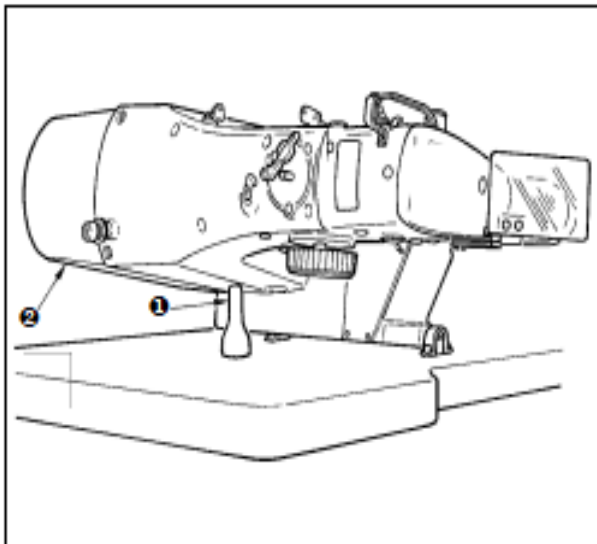

When tilting the sewing machine head, tilt the head gently until it comes in contact with head support rod **1**

CAUTION !

1. Before tilting the sewing machine head, make sure that head support rod **1** is attached to the machine table.

2. When raising the sewing machine head, do not raise it while holding motor cover **2** . It will be the cause of breakage of motor cover **2** .

3. Be sure to tilt the sewing machine head on a flat place to prevent it from falling.

8. Installing the operation panel

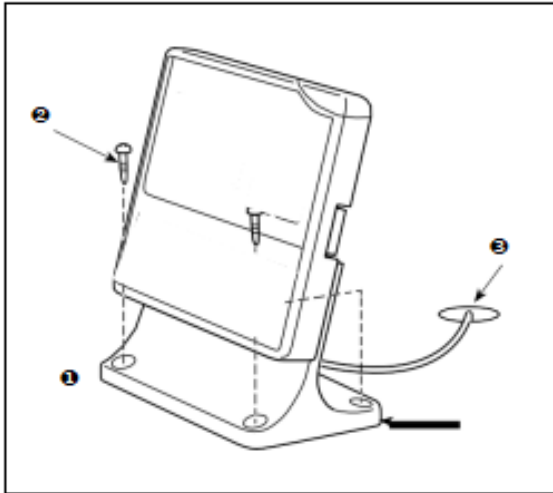

Fix operation panel mounting plate **1** on the table with four wood screws **2** . Then, pass the cable through hole **3** in the table.

9. Installing the eye protection cove

Be sure to attach this cover to protect the eyes from the disperse of needle breakage.

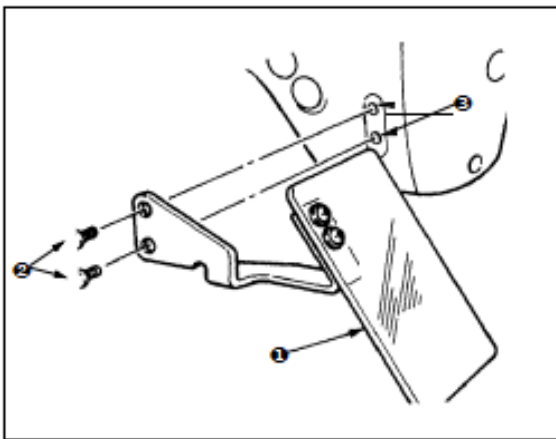

Be sure to use eye protection cover **1** after installing it on installing section **3** with screws **2**

10. Installing the thread stand

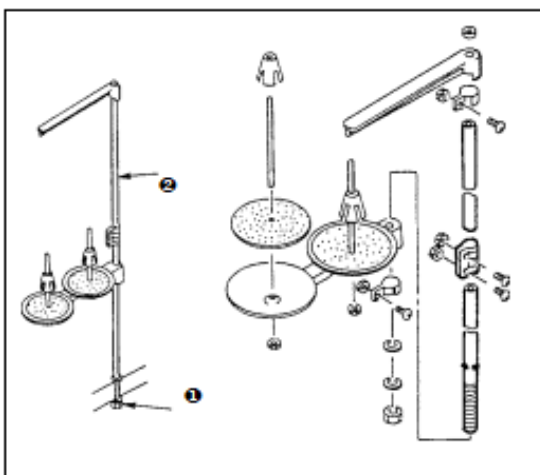

1) Assemble the thread stand unit, and insert it in the hole in the machine table.

2) Tighten locknut **1** to fix the thread stand.

For ceiling wiring, pass the power cord through spool rest rod **2**

III. OPERATION OF THE SEWING MACHINE

1. Lubrication

WARNING : Turn OFF the power before starting the work so as to prevent accidents caused by abrupt start of the

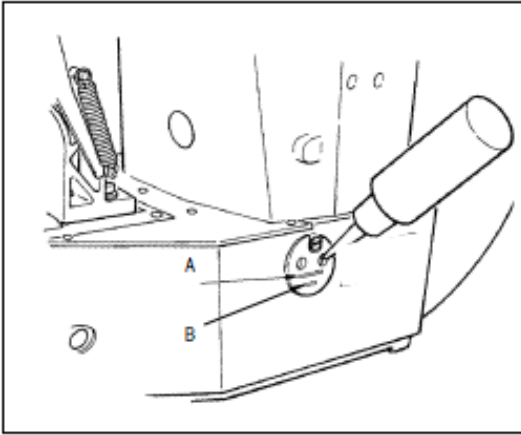

Check that the place between lower line B and upper line A is filled with oil. Fill there with oil using the oiler supplied with the machine as accessories when oil is short.

* The oil tank which is filled with oil is only for lubricating to the hook portion. It is possible to reduce the oil amount when the number of rotation used is low and the oil amount in the hook portion is excessive.

Caution!

1. Do not lubricate to the places other than the oil tank and the hook of caution 2 below. Trouble of components will be caused.
2. When using the sewing machine for the first time or after an extended period of disuse, use the machine after lubricating a small amount of oil to the hook portion.

2. Attaching the needle

WARNING : Turn OFF the power before starting the work so as to prevent accidents caused by abrupt start of the

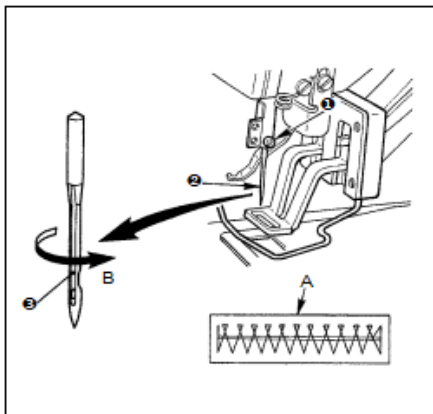

Loosen setscrew ❶ and hold needle ❷ with the long groove ❸ facing toward you. Then fully insert it into the hole in the needle bar, and tighten setscrew ❶ .

Caution!

If the stitches are made as shown in A, attach the needle facing to the direction B to a small extent.

3. Threading the machine head

WARNING : Turn OFF the power before starting the work so as to prevent accidents caused by abrupt start of the

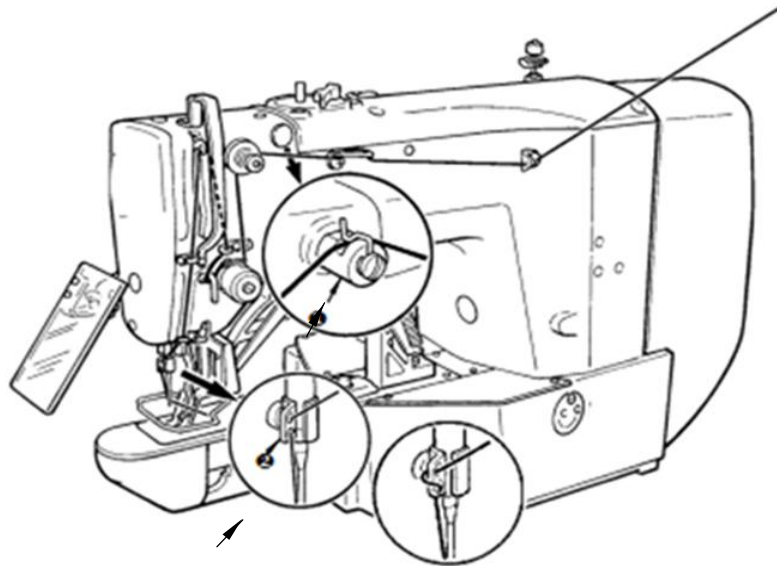

Pull out the thread by approximately 40mm from the needle after threading through the needle.

Caution!

1. When the silicon oil is used, thread through thread guide for silicon ❶ (Optional).
2. For thick thread, pass the thread through one hole only of needle bar thread guide ❷

4. Installing and removing the bobbin case

WARNING : Turn OFF the power before starting the work so as to prevent accidents caused by abrupt start of the

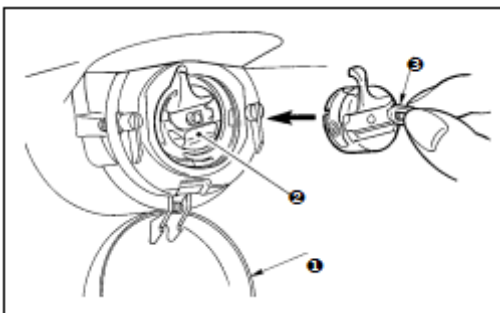

- 1) Open hook cover ❶ .
- 2) Raise latch ❸ of bobbin case ❷ , and remove the bobbin case.
- 3) When installing the bobbin case, fully insert it into the shuttle shaft, and close the latch!

Caution!

If it is not fully inserted, bobbin case ❷ may slip off during sewing.

5. Installing the bobbin

WARNING : Turn OFF the power before starting the work so as to prevent accidents caused by abrupt start of the

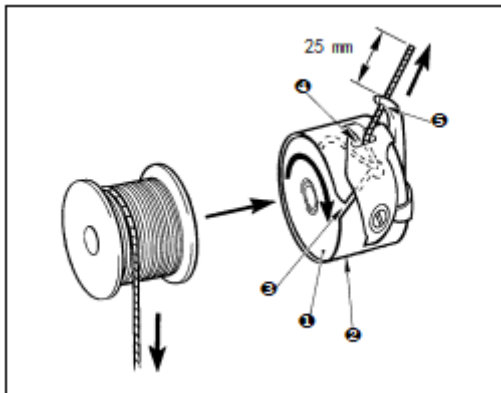

- 1) Set the bobbin ① into bobbin case ② in the direction shown in the figure.
- 2) Pass the thread through thread slit ③ of bobbin case ②, and pull the thread as it is. By so doing, the thread will pass under the tension spring and be pulled out from thread hole ④.
- 3) Pass the thread through thread hole ⑤ of the horn section, and pull out the thread by 25mm from the thread hole.

Caution!

If the bobbin is installed in the bobbin case orienting the reverse direction, the bobbin thread pulling out will result in an inconsistent state.

6. Adjusting the thread tension

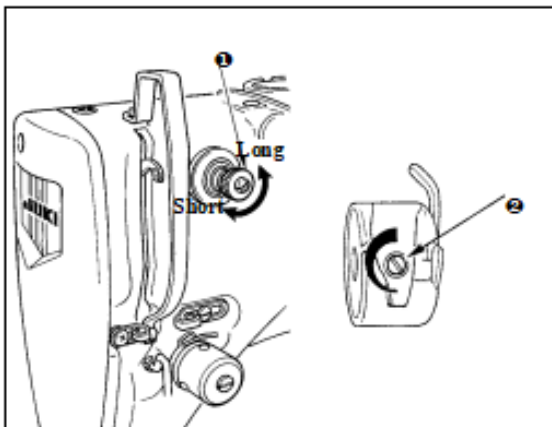

If thread tension controller No. 1 ① is turned clock-wise, the length of remaining thread on the needle after thread trimming will be shorter. If it is turned counterclockwise, the length will be longer.

Shorten the length to an extent that the thread is not slipped off.

Adjust needle thread tension from the operation panel and bobbin thread tension with ②

7. Adjusting the thread take-up spring

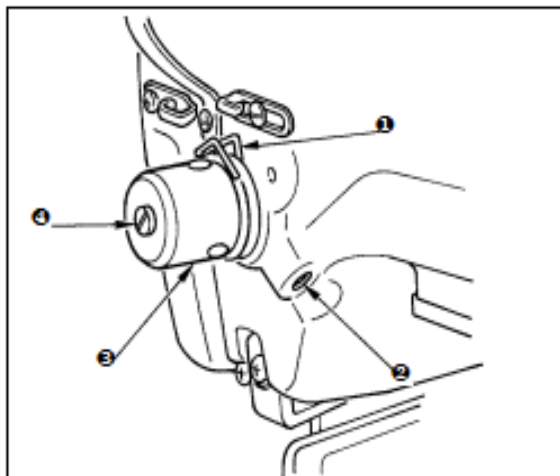

The standard stroke of thread take-up spring ① is 8 to 10 mm, and the pressure at the start is 0.1 to 0.3N.

1) Adjusting the stroke

Loosen setscrew ②, and turn thread tension asm. ③. Turning it clockwise will increase the moving amount and the thread drawing amount will increase.

2) Adjusting the pressure

To change the pressure of the thread take-up spring, insert a thin screwdriver into the slot of thread tension post ④ while screw ② is tightened, and turn it. Turning it clockwise will increase the pressure of the thread take-up spring. Turning it counterclockwise will decrease the pressure.

8. Example of the thread tension

When using the sewing machine for the first time, adjust the thread tension referring to the table below

Thread	Material	Needle thread tension setting	Thread take-up spring moving amount [Thread drawing amount]	Strength
Polyester filament thread #50	Wool	30 to 35	10mm [13mm]	0.1N
Polyester spun thread #50	Wool	50 to 55	10mm [13mm]	0.2N
Polyester spun thread #60 (Thread clamp OFF)	T/C broad	30 to 35	8 to 10mm [11 to 13mm]	0.1N
Cotton thread #50	Denim	35 to 45	10mm [13mm]	0.1N
Cotton thread #20	Denim	35 to 45	8 to 10mm [11 to 13mm]	0.1N

IV. MAINTENANCE

1. Adjusting the height of the needle bar

WARNING : Turn OFF the power before starting the work so as to prevent accidents caused by abrupt start of the

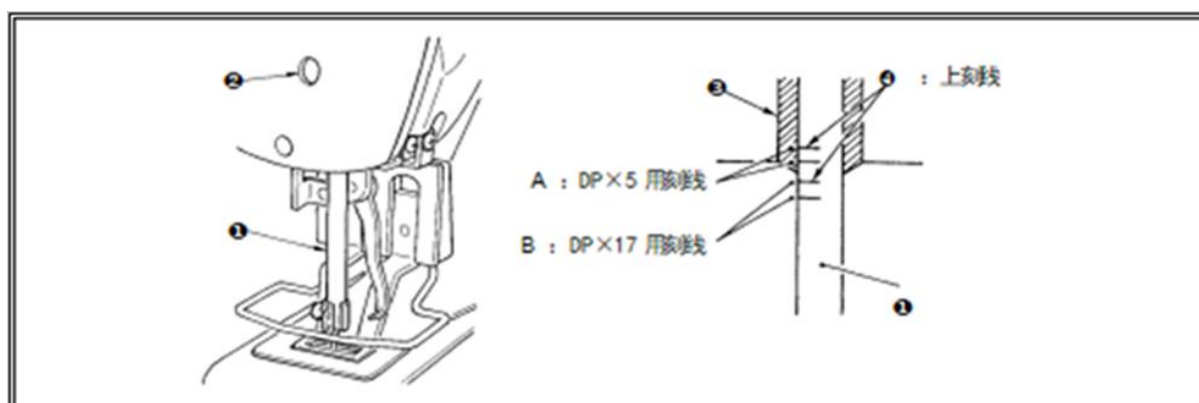

Bring needle bar ① to the lowest position of its stroke. Loosen needle bar connection screw ② and adjust so that upper marker line ④ engraved on the needle bar aligns with the bottom end of needle bar bushing, lower ③.

Caution!

After the adjustment, make sure that there is no uneven torque.

*When stitch skipping occurs in accordance with the sewing conditions, adjust the height of the needle bar so as to lower it by 0.5 to 1 mm from the needle bar engraved line ④

2. Adjusting the needle-to-shuttle relation

WARNING : Turn OFF the power before starting the work so as to prevent accidents caused by abrupt start of the

Relation between needle and engraved lines



1) Turn the handwheel by hand. When needle bar **1** has gone up, adjust so that lower marker line **2** engraved on the needle bar aligns with the bottom end of the needle bar bushing **3**, lower

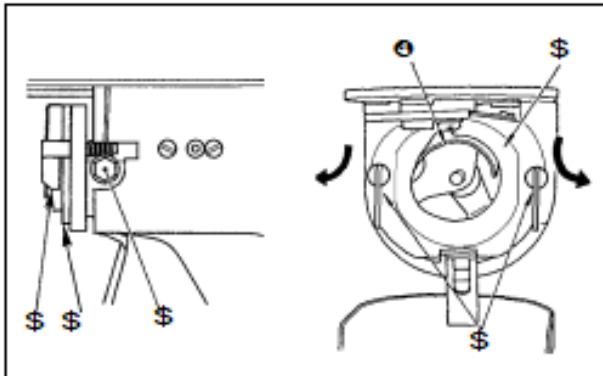

Loosen setscrew \$ in the driver. Open inner hook pressers \$ to the right and left, and re-move inner hook presser \$ Caution!

At this time, be careful not to let inner hook **4** come off and fall.

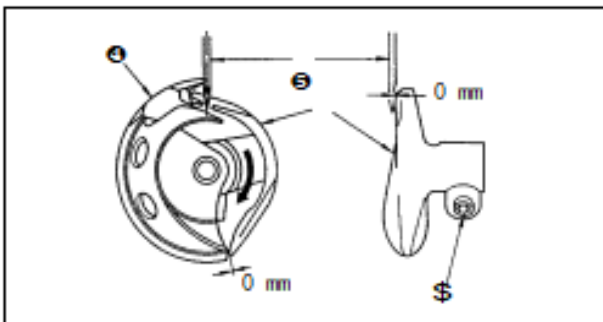

3) Adjust so that the blade point of inner hook **4** aligns with the center of needle **5**, and that a clearance of 0 mm is provided between the front end of the driver and the needle as the front end face of driver **6** receives the needle to prevent the needle from being bent. Then tighten setscrew \$ of the driver.

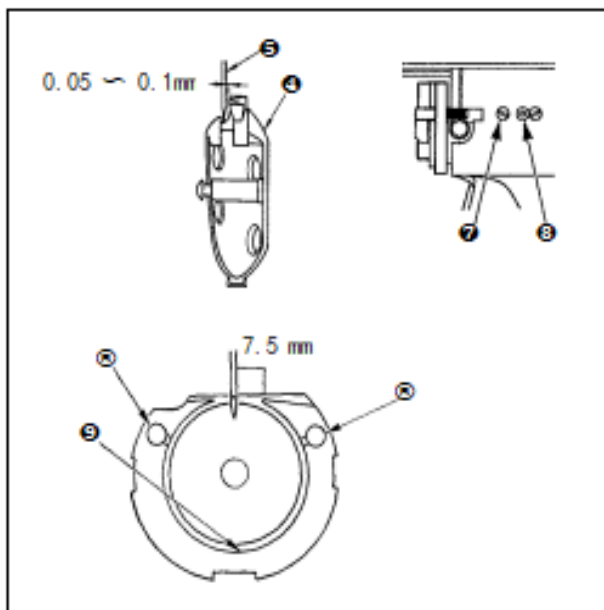

4) Loosen setscrew **7** of the shuttle, and adjust the longitudinal position of the shuttle. To do this adjustment, turn shuttle race adjusting shaft **8** clockwise or counterclockwise to provide a 0.05 to 0.1 mm clearance between needle **5** and the blade point of inner hook **4**.

5) After adjusting the longitudinal position of the shuttle, further adjust to provide a 7.5 mm clearance between the needle and the shuttle by adjusting the rotating direction. Then tighten set-screw **7** of the shuttle.

Caution!

If the sewing machine is left unused for a long time, or after clearing the area surrounding the hook section, apply a little quantity of oil to race section ⑨ and felt ⑩ before using the sewing machine.

3. Adjusting the lift of the work clamp foot

WARNING : Turn OFF the power before starting the work so as to prevent accidents caused by abrupt start of the

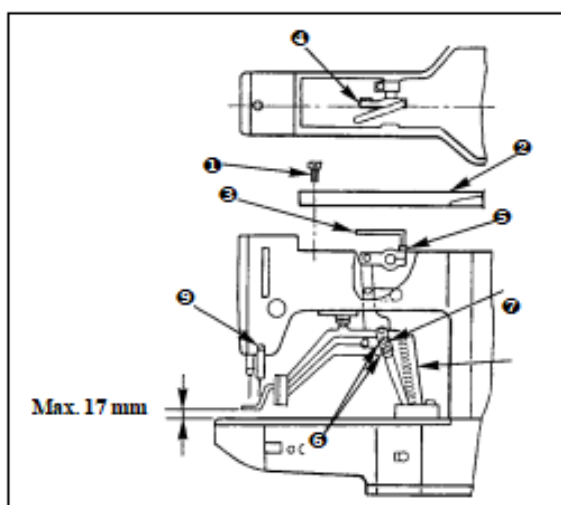

- 1) With the machine in stop mode, remove six set-screws ① of the top cover, and take off top cover ②.
- 2) Apply L-shaped wrench ③ to socket bolt ⑤ of clamp ④, and loosen the socket bolt.
- 3) Push down L-shaped wrench ③ to increase the lift of the work clamp foot, or pull it up to decrease the lift.
- 4) After the adjustment, securely tighten socket bolt ⑤.
- 5) If the right and left work clamp feet are not levelled, loosen fixing screw ⑥ and adjust the position of the work clamp foot lever support plate ⑦ to level them.

Caution!

At this time, be careful not to cause work clamp foot lever support plate ⑦ to interfere with feed bracket ⑧.

If the work clamp foot lever support plate interferes with the wiper, readjust the height of the wiper using setscrew ⑨ in the wiper installing base.

4. The moving knife and counter knife

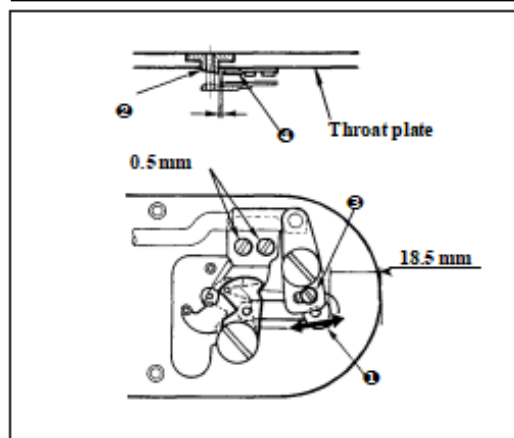

- 1) Loosen adjusting screw ③ so that a clearance of 18.5 mm is provided between the front end of the throat plate and the top end of thread trimmer lever, small ①. To adjust, move the moving knife in the direction of arrow.
- 2) Loosen setscrew ⑤ so that a clearance of 0.5 mm is provided between needle hole guide ② and counter knife ④. To adjust, move the counter knife.

5. Draining waste oil

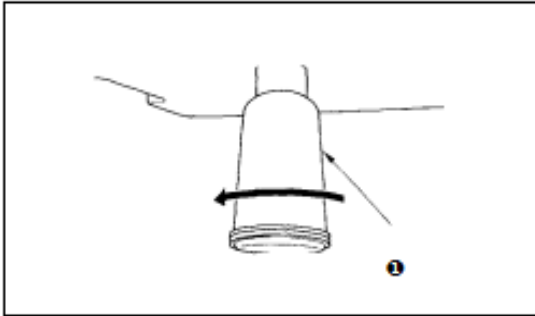

When polyethylene oiler ❶ becomes filled with oil, remove polyethylene oiler ❶ and drain the oil.

6. Amount of oil supplied to the hook

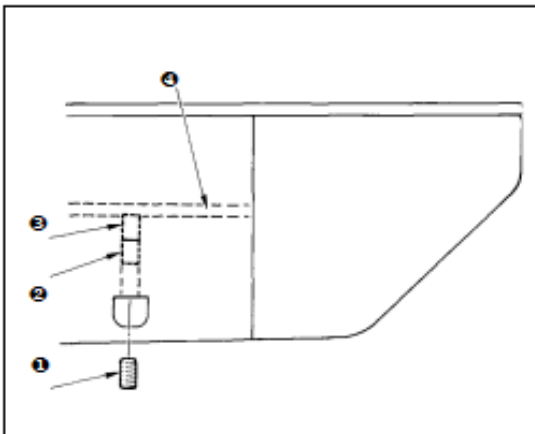

1) Loosen setscrew ❶ and remove setscrew ❶ .

2) When screwing in adjustment screw ❷ , the amount of oil of oil pipe, left ❹ can be reduced.

3) After the adjustment, screw in setscrew ❶ and fix it.

Caution!

1. The state of standard delivery is the position where ❸ is lightly screwed in and returned by 4 turns.
2. When reducing the amount of oil, do not screw in the screw at once. Observe the state for approximately half a day at the position where ❸ is screwed in and returned by 2 turns. If reducing is excessive, worn-out of the hook will result.